



Digital Actuator Interface
DeviceNet SERIES 52

On / Off Service

FEATURES

The Bray Controls Series 52 DeviceNet Digital Actuator Interface enables Pneumatic Valve Actuators to operate in On/Off service when connected to a DeviceNet network. Commands from the network can direct a Solenoid Air Valve to position the Valve Actuator fully open or fully closed. Actual valve position sensed by a Valve Status Monitor can be transmitted to other devices over the network. Module status, including both network and diagnostic information, can be transmitted over DeviceNet and visually displayed through LED indicators. Both power and data wiring are supplied through a single DeviceNet cable connection.

DeviceNet

DeviceNet is an economical fieldbus network used to connect industrial devices such as sensors, actuators and motors while providing access to the intelligence present in these devices. DeviceNet allows up to 64 devices to communicate with each other over a single cable that supplies both communication and power. This simplifies field wiring, enhances functionality, and reduces total system cost.

INTELLIGENCE

The Series 52 DeviceNet Digital Actuator Interface is microprocessor controlled, or *smart*, using firmware specifically designed to complement the capabilities and features of Bray Pneumatic Actuator Accessories. It reads two digital inputs (DI) from the Valve Status Monitor, and controls one digital output (DO) to the Solenoid Air Valve. The Process Controller or PLC communicates with all three digital I/O points through a single network address, or MAC ID. All three I/O points, as well as several diagnostic parameters, are continuously monitored and accessible through the DeviceNet connection.

OPERATION

The Series 52 DeviceNet Digital Actuator Interface is easy to install and configure. Network wiring is done through a single DeviceNet standard five-pin connector, similar to plugging a mouse or keyboard into a personal computer. Configuration is done with Electronic Data Sheet (EDS) files without adjusting potentiometers or selector switches. All configuration settings are saved in non-volatile memory so they will survive power outages. An entire Actuated Valve Assembly (shown above) requires only a single DeviceNet connector and one air supply connection to operate.

Bray Controls

SPECIFICATIONS

Mounting

The Series 52 DeviceNet Digital Actuator Interface housing has two 0.184" holes for remote mounting away from the actuated valve. When supplied as part of a Bray DeviceNet Actuated Valve Assembly, a mounting kit is used to attach the Interface to the top of the Pneumatic Actuator as shown in the cover picture. Weatherproof cables are used to connect the Interface to the Solenoid Air Valve and the Valve Status Monitor.

Electronic Data Sheet

The Series 52 DeviceNet Digital Actuator Interface includes an ODVA compliant Electronic Data Sheet (EDS) to simplify configuration. The EDS enables the user's configuration software to quickly communicate with all supported features of the Actuated Valve Assembly, and allows the user to remotely monitor status and diagnostic information.

Default Settings

The factory default settings are:

MAC ID: 63

Data Rate: 125 kbps

Diagnostics

An Input Fault will set bit 3. An Output Fault will set bit 4. Either type of fault will illuminate the Fault LED as a visual aid in troubleshooting.

Overcurrent Protection

If an input or output is subjected to a short circuit, perhaps due to miswiring, sensor problems or solenoid failure, the Interface will activate overcurrent protection to prevent damage.

Series 52 DeviceNet Digital Actuator Interface Specifications

Address Range	0 to 63 (Software Settable)																																
Network Data Rate	125, 250, or 500 kbps (Software Settable)																																
DeviceNet Messaging	Polled and Explicit Message Connections																																
Connectors	Bus: Five Pin Mini-Style Male Input: Four Pin Euro-Style Female Output: Four Pin Euro-Style Female																																
I/O Data	<p>Produced Data Size: 1 Byte</p> <table border="0"> <tr> <td>7</td> <td>6</td> <td>5</td> <td>4</td> <td>3</td> <td>2</td> <td>1</td> <td>0 (bits)</td> </tr> <tr> <td>-</td> <td>-</td> <td>-</td> <td>OF</td> <td>IF</td> <td>OS</td> <td>I-1</td> <td>I-0</td> </tr> </table> <p>I-0 = Input 0 (1 = Closed, 0 = Not Closed) I-1 = Input 1 (1 = Open, 0 = Not Open) OS = Output Status (1 = On, 0 = Off) IF = Input Fault (1 = Fault, 0 = OK) OF = Output Fault (1 = Fault, 0 = OK)</p> <p>Consumed Data Size: 1 Byte:</p> <table border="0"> <tr> <td>7</td> <td>6</td> <td>5</td> <td>4</td> <td>3</td> <td>2</td> <td>1</td> <td>0 (bits)</td> </tr> <tr> <td>-</td> <td>-</td> <td>-</td> <td>-</td> <td>-</td> <td>-</td> <td>-</td> <td>O-0</td> </tr> </table> <p>O-0 = Output 0 (1 = On, 0 = Off) Normal Operation: Output On turns the Solenoid Air Valve On and Opens the Valve</p>	7	6	5	4	3	2	1	0 (bits)	-	-	-	OF	IF	OS	I-1	I-0	7	6	5	4	3	2	1	0 (bits)	-	-	-	-	-	-	-	O-0
7	6	5	4	3	2	1	0 (bits)																										
-	-	-	OF	IF	OS	I-1	I-0																										
7	6	5	4	3	2	1	0 (bits)																										
-	-	-	-	-	-	-	O-0																										
LED Indicators	<p>Network Status: Solid Green - Allocated (Normal) Flashing Green - Not Allocated Red - Bus Fault Flashing Red - Poll Time-Out</p> <p>Input: Green - Input On</p> <p>Fault: Red - Input Fault and/or Output Fault</p> <p>Output: Green - On</p>																																
Input Connection (x2)	One 4 Wire PNP Dual Proximity Sensor or Two Dry Contacts. Short Circuit Protected. Maximum switch Frequency 200Hz.																																
Output Connection (x1)	0.15 Amp Short Circuit Protected. Maximum switch Frequency 200Hz.																																
Bus Power	11-25 VDC < 100 mA (Quiescent Current)																																
Housing	Material: Flame Retardant black ABS Ratings: UL94-5VA, NEMA 4/4X, IP 67																																
Operating Temperature	-25° to +70°C (-13° to +158°F)																																

DeviceNet Actuated Valve Assembly for On/Off Service

A typical Bray DeviceNet Actuated Valve Assembly for On/Off Service consists of a S20 (or S30) Bray Butterfly Valve, a Bray S90 (or S91) Pneumatic Actuator, a Bray S60 Solenoid Air Valve, a Bray S52 Valve Status Monitor, and connecting cables as shown in the cover picture.

INTERFACE

Series 52 DeviceNet Input/Output Interface Connection Diagram

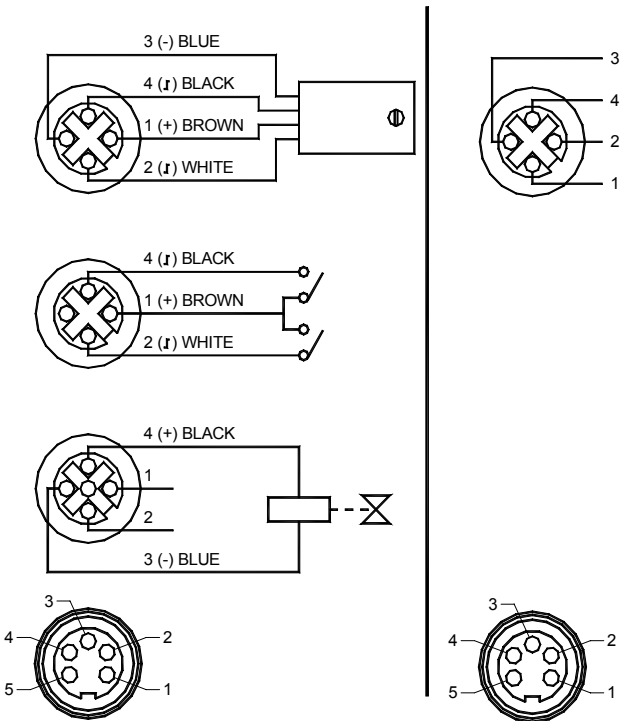
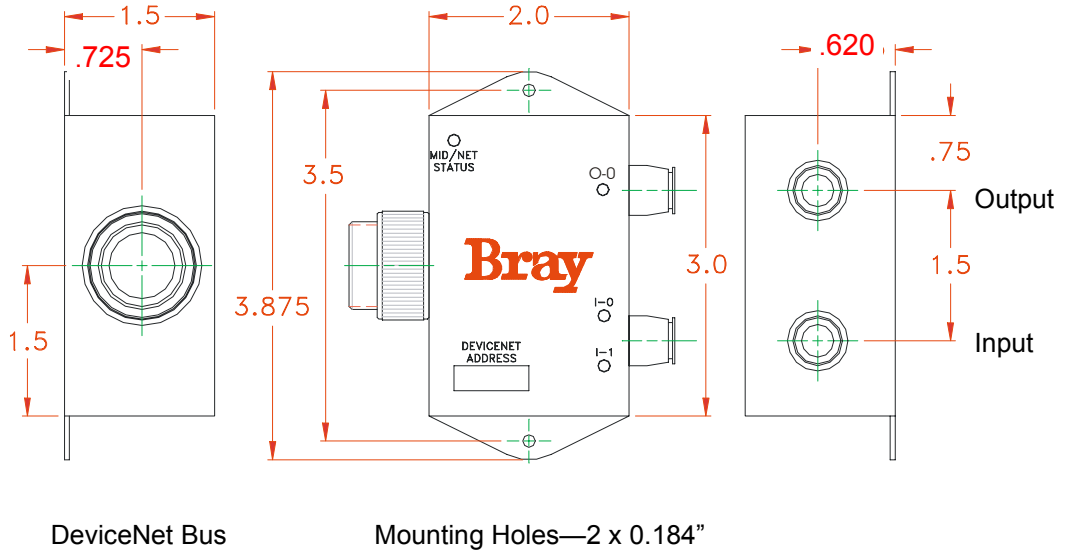

INPUT:

Series 52 PNP ProxSensor Valve Status Monitor

- 1 = V +
- 2 = Input Signal B
- 3 = V -
- 4 = Input Signal A
- 5 = Not Used

Alternate Dry Contact (x2)

OUTPUT:

Series 60 Solenoid Air Valve

DeviceNet BUS:

DeviceNet Five Pin Male Mini-Connector